

ANALYTICAL BALANCES AS



Balances series AS represent standard level of analytical balances. They are equipped with backlit LCD display. Accuracy and precise measurement of the balances are determined by internal calibration, dependant on time and temperature changes.

Analytical balances AS series are offered with following capacities: 110, 160, 220, 310 g with readability of 0,1 mg and 60/220 with readability 0,1/0,01 mg and 100 g with readability 0,01 mg.

GLP procedure of these balances is a report from calibration process of the balance, and this information has unchangeable shape (no modification possible). User has access to big measuring chamber with sliding doors and sliding top glass. Each balance is equipped with RS 232 output and possibility of connection of additional display as standard.

Balances have possibility of weighing loads under the weighing pan, i.e. under-hook weighing. In such case the mass of load is measured under the pan. It is an alternative for loads with non-standard dimensions, shapes and loads which create magnetic field. Under-hook weighing is also applied for density determination of materials.



Counting pieces



Density determination



Percentage



2 years warranty period

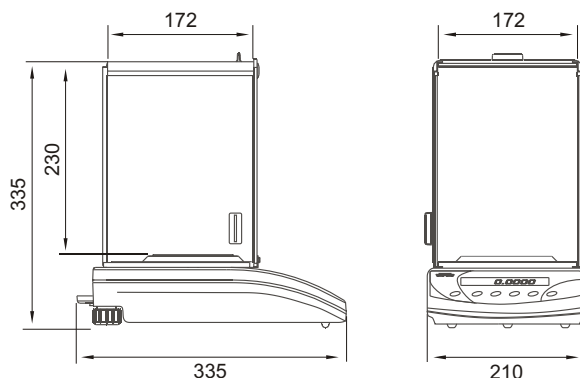

Technical data:

	AS 60/C/2	AS 60/220/C/2	AS 110/C/2	AS 160/C/2	AS 220/C/2	AS 310/C/2 *
Max capacity	60 g	60 g/220 g	110 g	160 g	220 g	310 g
Minimal load	1 mg	1 mg	10 mg	10 mg	10 mg	10 mg
Readability	0,01 mg	0,01 mg/0,1 mg	0,1 mg	0,1 mg	0,1 mg	0,1 mg
Tare range	-60 g	-220 g	-110 g	-160 g	-220 g	-310 g
Working temperature	+10° - +45°C					
Repeatability	0,02	0,02/0,1	0,1 mg	0,15	0,15	0,2
Linearity	± 0,05	± 0,05/0,2	± 0,3 mg	± 0,3	± 0,3	± 0,3
Sensitivity drift	2 ppm/°C in temperature +15° - +35°C					
Power supply	power adapter 230V 50Hz AC / 11V AC 380 mA					
Calibration	internal (automatic)					
Pan size	ø 85 mm					

* non-verified balance

Additional equipment:

ANTI-VIBRATION TABLE (MILD STEEL OR STAINLESS STEEL)	RACK FOR UNDER-HOOK WEIGHING
PRINTERS: KAFKA 1, KAFKA 1Z, KAFKA SQ	ADDITIONAL LCD DISPLAY
PRINTER EPSON: TM-U220D, TM-U220B, TM-U220A	EXTERNAL RECHARGEABLE BATTERY WITH CHARGER
DENSITY KIT FOR SOLIDS AND LIQUIDS	COMPUTER SOFTWARE: PW-WIN 2005, RAD-KEY 2000, REC-FS 2000

RADWAG

26-600 Radom • Bracka Street 28 • POLAND • Phone: +48 48 3848800 • Fax: +48 48 3850010 • www.radwag.com • e-mail:export@radwag.com