

# MWP SERIES

## Micro Weighing Scale

High accuracy  
 Total 8 Units available (g, ct, lb, oz, GN, ozf, dwt, tl)  
 Counting, Weighing, Percentage Function Modes  
 Auto blue backlight (80hours continuous use)  
 RS-232 serial interface (PC, Printer)  
 Wind shield included



# MWP SERIES Micro Weighing Scale

### FEATURES

- High accuracy
- Total 8 Units available (g, ct, lb, oz, GN, ozf, dwt, tl)
- Counting, Weighing, Percentage Function Modes
- Auto blue backlight (80hours continuous use)
- Built-in rechargeable battery
- RS-232 serial interface (PC, Printer)
- Wind shield included
- Over load alarm function
- Auto power off function
- Auto span calibration & Auto zero tracking

### LARGE PLATTER



### DIMENSIONS

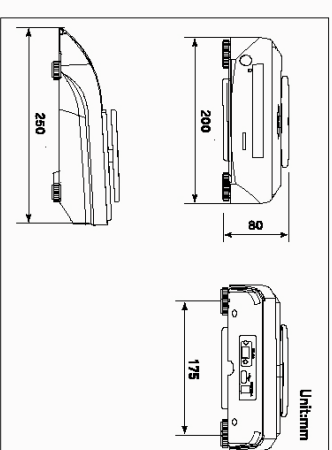

### SPECIFICATIONS

Model	MWP-N	MWP-H
Weighting Capacity	50, 100g, 200, 500g, 800, 100g 1500, 200g, 3000, 0.1g	300, 500g, 600, 800g 1200, 100g, 3000, 0.05g
Maximum Displayed Resolution	1 / 30, 0000	1 / 60, 0000
Application Modes	Weighing, Counting and Percentage (%)	
Display	6 digits LCD 160 95mm with Auto Backlight	
Operating Temperature	0°C ~ +40°C	
Power Source	AC Adapter, 12V/0.500Ah, Hermet Rechargeable Lead Acid Battery	
Battery Life	80 Hours Continuous Use with 12 Hours Recharge Time	
Interface	RS-232 or USB Output (Optional)	
Platter Size (mm)	191g-400g : 116, 1200g-3000g : 124, 144	
Dimensions (mm)	200(W) 250(D) 80(H)	
Product Weight	1.1kg (Net)	

### OPTION

- USB Interface
- Auxiliary LCD Display



CAS BLDG., # 440-1, SUNGNAE DONG,  
 GANGDONG GU, SEOUL, KOREA  
 TEL. 82 2 2225 3500  
 FAX. 82 2 475 4648  
<http://www.globalcas.com>

Specifications are subject to change for improvement without prior notice.